

**CASE 410/420
SKID STEER
INSTALLATION INSTRUCTIONS**



PHONE (519) 485-5961 OR 1-800-267-2665
FAX (519) 485-3745 OR 1-888-267-3745

COMPRESSOR



Engine lift bracket

Fan screen

- 1) Remove the fan screen
- 2) Remove engine lift bracket
- 3) Remove bolt from top of valve cover with small "P" clamp.



Install add on pulley with three 10MM bolts provided in kit.



Loosen bracket from front of engine to muffler support.
Temporarily remove.



Tightener bracket for
compressor.

Leave this bolt loose.

Install compressor mount as shown with supplied hardware.



Tightener bracket. (One or two washers may be required to obtain correct spacing for tightener.)

Exhaust bracket re- installed after compressor tightener bracket.

Install compressor as shown. (note heater hose routing)
Install belt and tighten compressor and mount.
RE-install exhaust bracket and tighten.



Exhaust bracket re-installed. Washers may be required to obtain proper alignment.

CONDENSER



The condenser will mount beneath the engine cover and the fan to help cool it will be mounted on the top of the engine cover above the condenser.



Install the fan as shown with the hardware provided. Button head bolts up from underneath lid with locks and nuts at the fan. You will likely need to drill holes slightly to align with the fan holes.



Install the condenser as shown beneath the lid. It bolts from the top through the lid.

EVAPORATOR



Remove cover from top of machine. The evaporator will be installed beside the existing heater coil.



Drain pan
hole

Drain tube

Drain pan

Drain pan holes.

Set the evaporator drain pan in place. Mark the location of the two drain tubes and drill holes to allow the tubes to stick through.





Evaporator

Expansion valve

Install the evaporator coil and drain pan as shown.

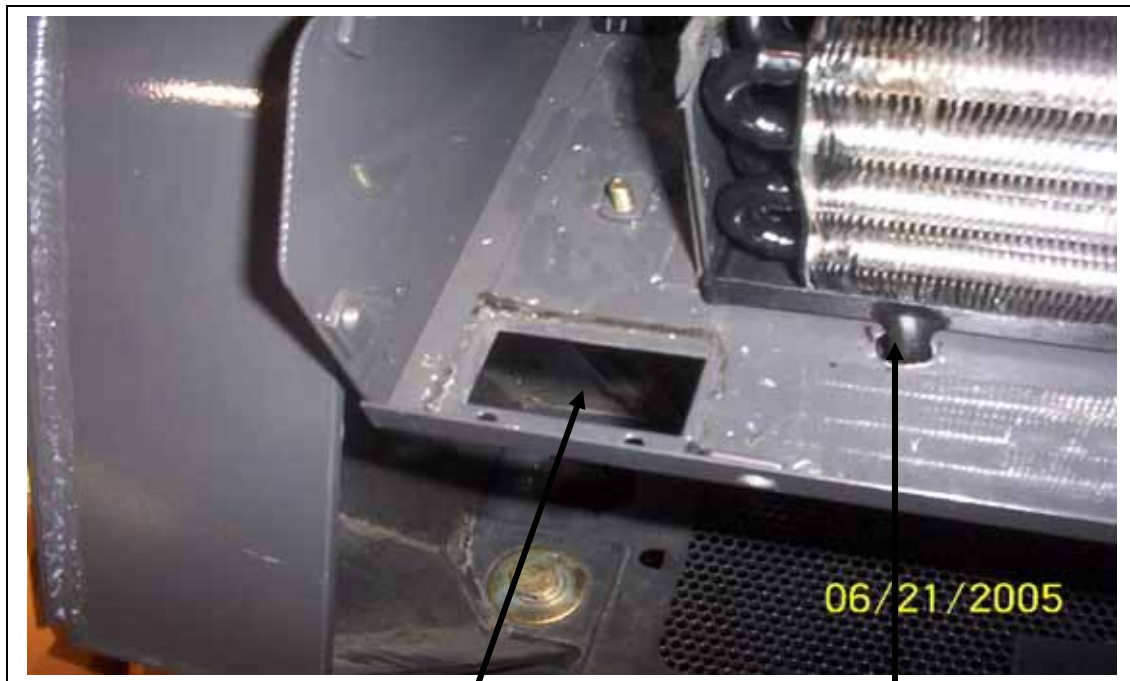

Hoses will be routed through here.

Drain tube

RECEIVER DRIER



Receiver drier

Binary pressure switch

Install receiver drier as shown. Mounting bracket and hardware provided in kit.

HOSE RUNS



Knock out at left side behind rear window. Install trim as shown.



5/16" hose to receiver drier.

Hose wrap all hoses.

1/2" hose to compressor



Hose run from evaporator through the knock outs. Run the electrical from the thermostat to the binary at the drier at the same time.



Hose run with cab lifted. "P" clamp as shown.



Trim around this hole
before running hoses.

Hose run through cab
wall.

Protective sheath.



“P” clamp hoses as shown along lower part of cab. A cover plate is not provided in this kit, but is available from the Case dealer.



Remove floor plate to allow hose run. Hoses must run around the pivot point of cab hinge as shown. (similar to heater hose arrangement on other side)



Trim this hole also



13/32 hose to condenser

Compressor

1/2" hose to evaporator



Hoses connected at condenser.



A/C hoses

Drain tubes

Heater hoses

ELECTRICAL



A/C on-off switch



Black and blue wires exist behind the panel where the A/C switch is located. Alternate wire connector provided in the kit.



Thermostat located at the evaporator.

The wire to feed the thermostat power exists in the harness. Use a test light with the key on and the a/c switch on to identify the correct wire.

Install thermostat as shown.

Connect the long wire in loom assembly to the other terminal on the thermostat. The other end of this wire connects to the binary switch located on the receiver drier.

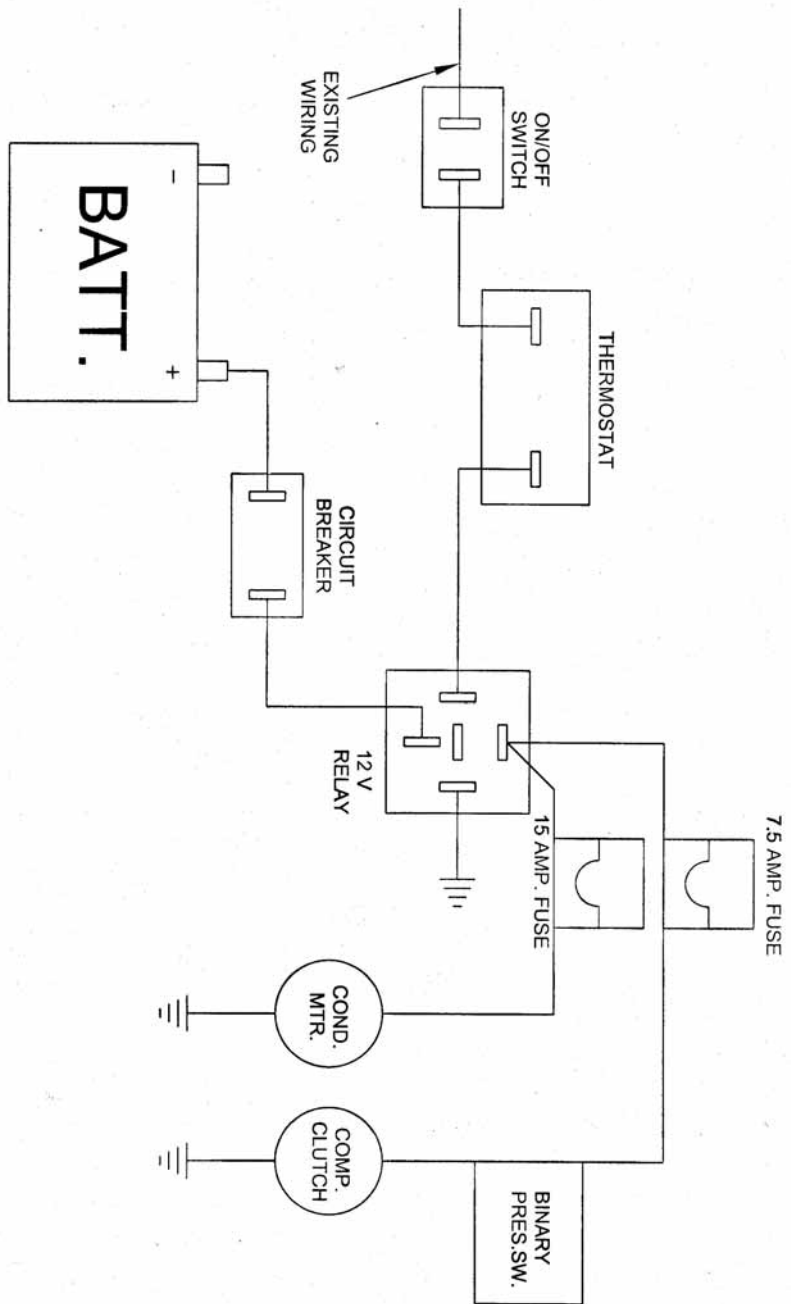

WITH EXISTING HEAT

	DRAWING TITLE:	410 WIRING DIAGRAM
	DRAWN BY:	J.S.
	APPROVED BY:	J.L.
	MODIFIED ON:	NOV. 14, 2005
	REV:	0
UNITS:	S.A.E.	

CHARGING AND TESTING

- 1) Pressure test the system using nitrogen to a pressure of 250 psi. Check for leaks.
- 2) Add 2oz of SP20 Sanden PAG oil to the system.
- 3) Vacuum the system for at least ½ hour.
- 4) Check that the vacuum holds.
- 5) Fill the system with approx 2.5lbs of R134a refrigerant. **DO NOT USE ANY OTHER TYPE OF REFRIGERANT OR IT WILL VOID THE WARRANTY.**
- 6) Test the system. Check the cycling temperature of the thermostat. Adjust the thermostat settings if required to avoid coil freeze up problems. See the thermostat setting procedures at the end of these instructions.

Refrigerant Flow Pattern in a Standard Air Conditioning System

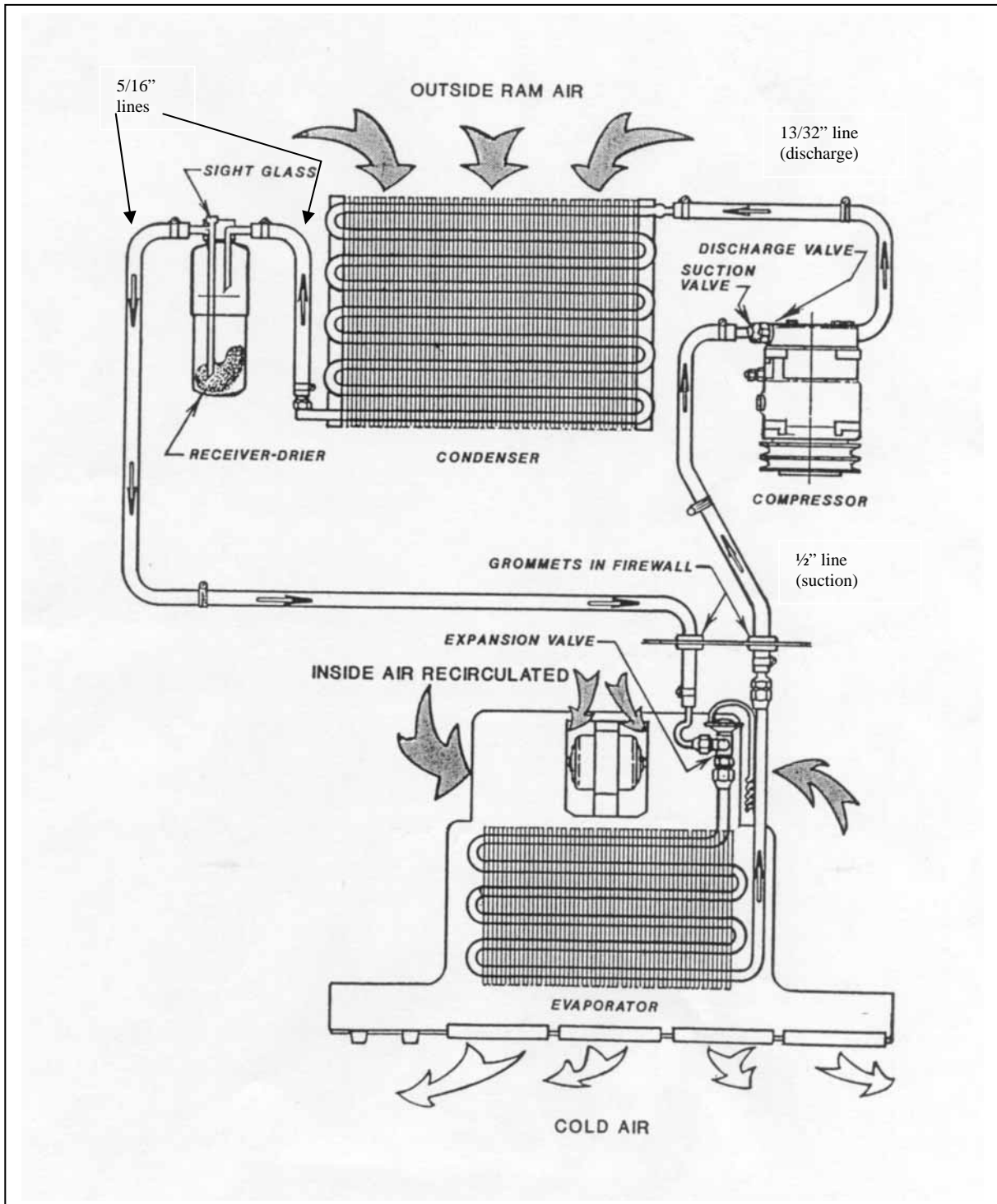

Thermostat Setting Procedures

- 1) Thermostat types
 - a) preset
 - b) adjustable
 - a) A preset thermostat is adjusted to its specific cut in and cut out temperatures when manufactured and does not have a rotary adjustment for the operator.
 - b) An adjustable or rotary thermostat has been manufactured to a predetermined cut in and cut out temperatures, but it is also operator adjustable to achieve the desired comfort level.

Both types of thermostats can have their factory settings adjusted by turning the setting screws on the body of the thermostat. One body type has the setting screws mounted externally and labeled for direction of rotation. The other body type requires the removal of the plastic end plate to expose the set screw.

- 2) Thermostat probe location: The location of the thermostat probe in an evaporator coil can be very important to achieve the maximum cooling potential of the coil while also preventing coil freeze-up. There is no set location for the thermostat probe to be put that will be optimum for all systems, but several rules of thumb may be followed:
 - a) Insert the probe in the coldest area of the evaporator coil.
 - b) Insert the probe from the top of the coil down, if possible.
 - c) Make sure that at least the last 3" of the thermostat probe are in the coil.

To find the most likely area where the coil is the coldest, consider these factors:

- 1) Direction of air flow through the coil.
 - 2) The coil area likely to have the lowest air flow.
 - 3) The inlet locations of the refrigerant into the coil.
 - 4) The inlet of the hotter outside air into the coil area.
-
- 1) Usually the coldest side of the evaporator coil will be the air outlet side. Often the thermostat probe can be inserted between the last and second last row of tubes.
 - 2) The lower air flow area of the evaporator coil in most systems tends to be near either end of the coil. These areas will be colder
 - 3) The area of the coil that the refrigerant inlet tube(s) occupy should be the coldest part of the coil.
 - 4) If the system is equipped with an outside air intake, where and how that air is brought into the evaporator area can have a large effect on the coil temperature. If all the outside air is piped into the evaporator in one area, that area will be considerably warmer in hot weather.

By looking at all these different factors, the area of an evaporator coil most likely to be the coldest can be determined.

Once the probe is inserted, the A/C system needs to be tested. Run the system to ensure that the thermostat is cycling the compressor off at the appropriate temperature. A core temperature ranging between 25° and 30° F should cause the thermostat to cycle off. The air temperature at the vent outlet closest to the evaporator coil should be between 38° F and 45° F when the compressor cycles off.

If the thermostat doesn't cycle off after a reasonable cool down period, and the air outlet temperature has dropped below 40° F, the cut in and cut out settings should be adjusted until the compressor is cycling on and off regularly. Let the system run for a decent time period (at least 15 min) and then check the evaporator coil for any signs of freezing.

Aeroquip E-Z Clip Assembly Instructions

Step 1. Cut the hose to proper length with an appropriate cutting tool. Aeroquip's hand held hose cutter has been specially designed for cutting all non-wire reinforced hose, such as GH-134 Multi-Refrigerant hose. Be sure the cut is made square to the hose length.

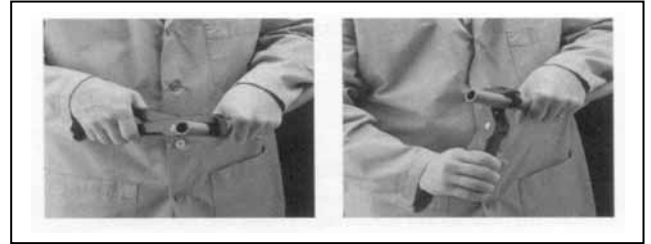

Step 2. Install two proper-sized clips onto the cut end of the hose. Orientation of the clips does not affect the performance of the connection. However, for ease of assembly, both clips should have the same orientation. NOTE: Failure to slide the clips over the hose at this time will require the clips to be stretched over the hose or fitting later. This may permanently damage the clip.

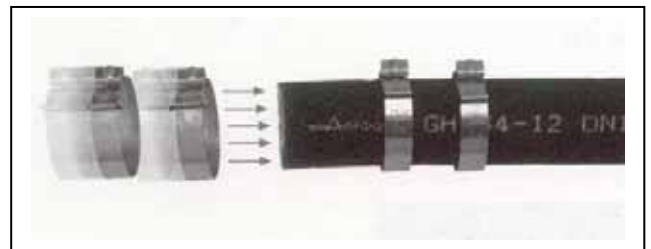

Step 3. Lubricate the nipple with a generous amount of the refrigeration or A/C system's compressor lubricating oil. This MUST be done to lower the force of nipple insertion.

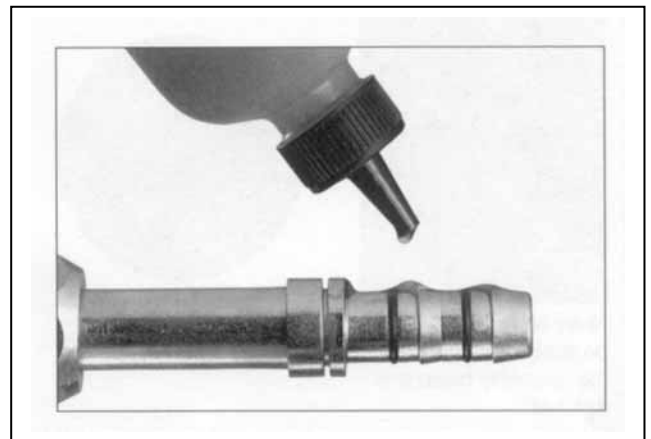

Step 4. Insert the nipple into the hose. To ensure that the nipple is fully inserted, check the gap between the cut end of the hose and the shoulder on the nipple. Care should be taken to avoid kinking or other damage to the hose during nipple insertion. NOTE: Be sure to wipe excess oil from the nipple and hose.



Step 5. Snap the cage into the groove on the nipple. The arms should extend over the hose length. When the cage has been correctly installed in the cage groove, the cage will be able to rotate in the groove. This step **MUST** be performed to ensure:

1. The clips will be located over the O-rings on the nipple.
2. The connection will be compatible with the connection's pressure rating.

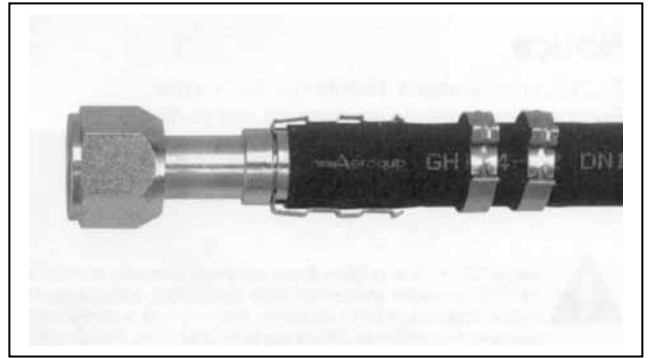

Step 6. Slide the clips over the cage arms and into the channels on each arm.

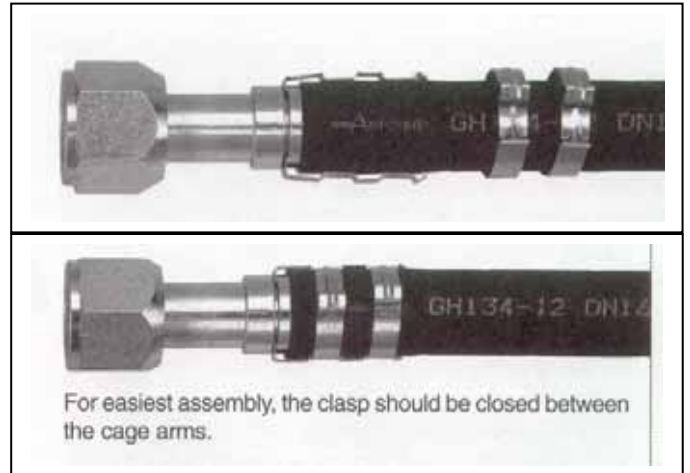

Step 7. Use the pliers to close the clips. The pliers should be positioned squarely on the clip connection points and should remain square during the closing of the clip.

NOTICE: E-Z Clip components should not be reused.

